

MAGNETIC FLOWMETER

Series MFX

Hot-Tapped Insertion Probe



Series MFX Insertion MagProbe™ Flowmeters feature the world's most advanced magnetic flow measurement technology available. Digital signal processing provides a measuring system with unsurpassed accuracy, versatility, low cost of installation and low cost of ownership. The MFX system installs quickly into liquid piping systems and can be configured and operational within minutes. MagProbe's exclusive venturi-notched tip assures accurate and stable flow readings, even when poor system hydraulics, flow swirl or very low flow rates are encountered.

MFX is designed for permanent installation in full-pipe liquid systems. The hot-tapped probe can be installed and retracted from service without interrupting the process stream. Other features include: bi-directional flow measurement, continuous intelligent diagnostics, four-line backlit alpha-numeric display, tactile keypad, optically isolated input-output busses and field replaceable duplex communication I/O modules. MFX flow measurement systems are a cost effective, versatile, investment that can be readily configured for piping from 1.5 inches [38 mm] to 120 inches [3048 mm].

Features

- An exclusive feature of MagProbe™ is the venturi-notched tip. The tip design provides increased accuracy and stability – eliminating the errors due to cross-flows and rotational flows that are common in large pipes.
- Field replaceable, optically isolated, I/O modules reduce the probability of significant damage in the event of an electrical surge.
- Low power consumption. The MFX system operates on less than 3W, allowing operation on UPS, solar panel and battery operated power sources.
- The measurement range of the MFX system is 600:1. Reading accuracy and reliability, especially at low flow rates, are improved versus mechanical, differential pressure and vortex shedding flowmeter performance.
- The MagProbe™ insertion probe can be installed and removed from service without turning off pumps or draining piping – eliminating down time.
- User configurable rate and totalizer units include: Feet, Gallons, FT³, Mil-GAL, Barrels, Acre-Feet, Pounds, Meters, Liters, M³, Mil-Liters and Kilograms.
- Field replaceable I/O module options include: 200K-event data logger, 4-20 mA input and output, rate pulse, dual relay, RTD-BTU, RS232C and RS485.
- Continuous intelligent diagnostics are performed to warn users of liquid or system problems that can influence performance.

Principles of Operation

The MagProbe is a point-velocity measuring device used primarily for measuring electrically conductive liquids, such as water and water-based fluids, in closed piping systems. The unit operates utilizing Faraday's principle of magnetic conduction, whereby a moving conductor (the liquid) has a voltage imposed on it that is directly proportional to two variables — the strength of a local magnetic field and the velocity of the moving conductor.

$$\text{Imposed voltage} \propto \text{Magnetic field} \times \text{Fluid velocity}$$

If the strength of the magnetic field is held constant, then the magnitude of the voltage will be proportional to the velocity of the moving conductor. The equation then simplifies to **Imposed voltage \propto Fluid velocity**. Most modern magnetic meters, including the MFX, apply tri-stated, alternating polarity DC pulses to an integral electromagnet. **See Figure 1.** Voltage measurements are made with the magnet off, to measure ambient background noise, and then with the magnet on in both polarities. The magnitude difference in voltage measured is proportional to flow. Once fluid velocity is measured, then various volumetric flow measurements can be obtained if the pipe internal diameter (I.D.) is known.

Point-velocity flowmeters measure the fluid velocity at a specified depth into the fluid stream, typically 1/8 of the pipe I.D., which has been proven to be the nominal velocity point when symmetrical flow profiles are present. This assumption requires the probe to be certain numbers of pipe diameter downstream of any piping condition (elbows, valves, thermo-wells, tees, etc.) that can cause flow abnormalities. Typically, a minimum of 15 pipe diameters of straight pipe is required to develop a symmetrical flow profile. Systems where symmetrical flow profiles are not present can still be measured accurately, but flow profiling (determining the average fluid velocity position in a pipe by measuring actual velocity at several cross-sectional positions in the pipe) must be performed to determine proper probe insertion depth. Exclusive to the MagProbe design is the venturi-notch tip, which provides superior performance when compared to other blunt and flat-tip designs. The venturi-notch eliminates measuring errors due to cross and rotational flows that are common in large pipes. **See Figure 2.**

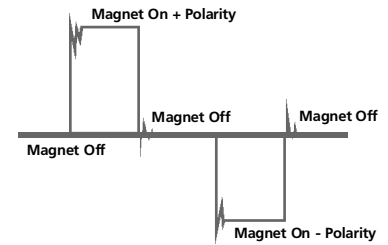

Figure 1 - Magnet Excitation

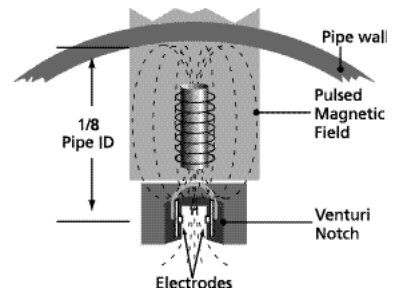
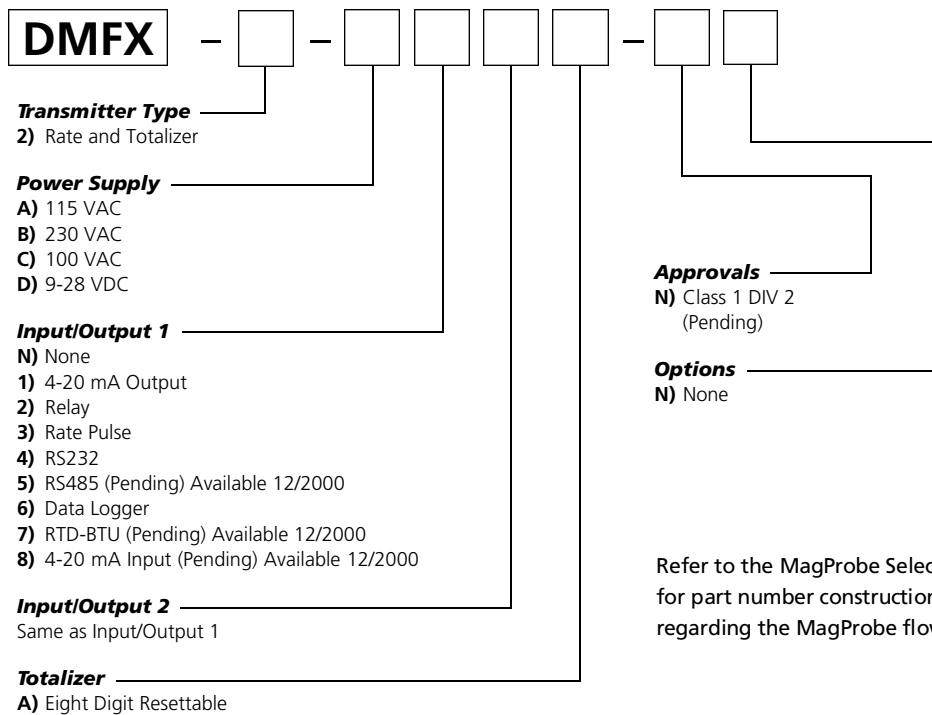

Figure 2 - MagProbe Design

Part Number Construction



Refer to the MagProbe Selection page for part number construction and options regarding the MagProbe flow meter.

Specifications

TRANSMITTER

| DESCRIPTION | SPECIFICATION |
|-----------------------------|--|
| POWER REQUIREMENTS | 115/230 Vac 50/60 Hz $\pm 15\%$ @ 5 VA max.; 9-28 Vdc @ 3 VA max. |
| VELOCITY RANGE | -30 to +30 feet/second [-9 to +9 meters/second]; minimum flow 0.05 fps [0.015 mps] |
| INPUTS/OUTPUTS | All modules are optically isolated from earth and system grounds. A maximum of two modules may be installed. |
| Optional | <p>4-20 mA Output: 800 ohms max; 12-bit resolution; user configured for either internal or external power; can be spanned anywhere in the velocity range</p> <p>Relay: two separate Form C relays, 200 Vac @ 0.5A resistive maximum</p> <p>Pulse Output: 0-10,000 Hz; 0.21 ohm resistance; 9 A max.; can be spanned anywhere in the velocity range</p> <p>RS232C: data rates to 57.6k; Modbus protocol</p> <p>Data Logger: 200,000 event; up to 8 separate data files; 16-bit resolution; integral DB-9 connector for plugging into PC; can be removed and installed without disconnecting system power</p> |
| Pending (Available 12/2000) | <p>RTD-BTU: supports two, three-wire, 1000 ohm RTDs, multiplexed, 12-bit resolution</p> <p>4-20 mA Input: 24 Vdc sensor excitation, 12-bit resolution, 2-channel</p> <p>RS485: supports up to 119 drops on three wires; 57.6k max baud; Modbus protocol</p> |
| DISPLAY | 4 line X 20 character alphanumeric LCD; LED backlit; nominal character size 0.19 inches [4.8 mm] height |
| UNITS: | User Configured |
| Engineering units | Feet, gallons, cubic feet, million gallons, barrels, acre-feet, pounds, meters, cubic meters, million liters, kilograms |
| Rate time intervals | Seconds, minutes, hours and days |
| TEMPERATURE RANGE | -40 to 185°F [-40 to 85°C], 0-95% relative humidity, non-condensing |
| ENCLOSURE | NEMA 4X [IP-65] polycarbonate, SS, brass and plated steel; 7.00H x 5.75W x 3.88D inches [178H x 146W x 99D mm] |
| ACCURACY | $\pm 1\%$ of actual flow rate at rates > 11 fps [0.3 mps]; ± 0.01 fps [0.003 mps] at rates < 11 fps [0.3 mps] |
| SENSITIVITY | ± 0.005 fps [± 0.0017 mps] |
| RESPONSE TIME | 0.3 to 30 seconds, user configured, to 100% of value, step change in flow |
| SECURITY | Keypad lockout, access code enable |
| APPROVALS | IEC 31326-1 for unattended continuous operation (pending); Class 1 Div 2 Groups C&D, Class 2 Div 2 Groups E-G (pending) |
| DIAGNOSTICS | Warning: probe impedance out of standard operating window (coated with conductor or insulator); power failure occurred; datalogger is low on memory or out of memory. Failure: coating on the probe has reached a level where reliable measurements cannot be made; magnet or wiring failure; flow velocity out of range. |

TRANSDUCER

| DESCRIPTION | SPECIFICATION |
|-------------------------------|---|
| PIPE SIZES | Internal diameters 1.50-120 inches [38-3048 mm]; DMP2-DMP5 require 1-1/2" NPT port; DMPA and DMPB require 1" NPT port |
| LIQUID REQUIREMENTS | Liquids with conductivity > 1 micro-Siemens/cm; liquids with solids that will not coat or wrap around the probe tip |
| TRANSMITTER TO PROBE DISTANCE | Up to 990 feet [297 meters] |
| ENVIRONMENT | -40 to 225°F [-40 to 105°C], NEMA 4X; Optional NEMA 6 |
| MATERIALS OF CONSTRUCTION | 316 Stainless Steel, PVDF, Viton®, PVC jacketed cable rated for outdoor and direct-burial use Electrodes: 316 SS, optional Hastelloy C and tantalum |
| OPERATING PRESSURE | DMP2 – DMP5 700 PSIG [48 BAR] MAX @ 25°C DMPA – DMPB 150 PSIG [6.8 BAR] MAX @ 25°C |
| VELOCITY RANGE | DMP2 – DMP5 to 30 fps [9 mps] all pipe sizes DMPA – DMPB to 30 fps [9 mps] pipes smaller than 36 inches [900 mm]; to 20 fps [6 mps] pipes greater than 36 inches [900 mm] |
| PRESSURE SENSOR | Optional; 0-200 PSIG, NEMA 6, requires 4-20 mA Input ISO-MOD |

MagProbe Selection

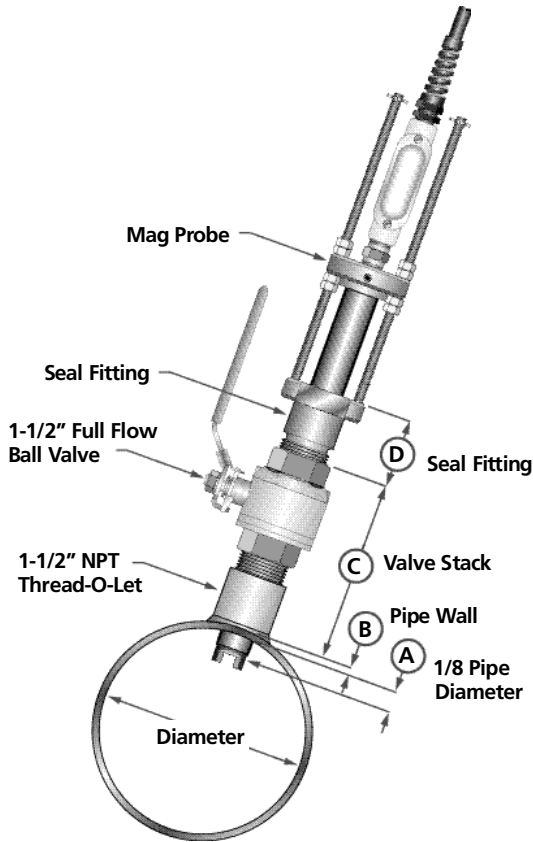

Probe Length Selection Procedure

Before purchasing a MagProbe insertion flow meter, it is necessary to calculate the probe length required for a particular piping system. In order to complete this calculation, some knowledge of the piping system must be known. The variables required are:

- Pipe internal diameter
- Pipe wall thickness
- The length of the valve stack
- Amount of straight pipe diameters in the system

Using this information and referring to the picture to the left, a minimum probe length can be determined.

Measurement A – The typical depth that the MagProbe tip is inserted into the piping system is 1/8 of the pipe internal diameter. Assume 1/8 of the pipe internal diameter unless a system piping configuration does not have at least 15 pipe diameters of straight pipe in the installation area. In that case, assume 1/2 of the pipe internal diameter—this will allow for flow profiling to be performed.

Measurement B – Pipe wall thickness. This information can be obtained from standard pipe wall charts or, ideally, can be measured using an ultrasonic wall thickness gauge.

Measurement C – Estimate the height that is going to be taken up by the pipe tap, nipple and full-flow ball valve. DMP2 through DMP5 probes utilize 1-1/2" NPT hardware, DMPA and DMPB utilize 1" NPT hardware.

Measurement D – The insertion fitting for DMP2 through DMP5 probes is 2.5 inches. The DMPA and DMPB is 5.25 inches.

$$\text{Minimum Probe Length Required} = A+B+C+D$$

MagProbe Part Number Matrix

1-1/2" Dura MagProbe

DMP - [] - [] [] [] - [] [] [] [] - []

Probe Length

- 2) 18 inches [457 mm]
- 3) 28 inches [711 mm]
- 4) 38 inches [965 mm]
- 5) 48 inches [1220 mm]

*Consult Factory for Longer Lengths

Cable Length

- 020) 20 feet [6 m]
 - 050) 50 feet [15m]
 - 100) 100 feet [30 m]
- Maximum Length: 990 feet [297 m]
in 10 ft. [3 m] increments

Conduit Type**

- N) None - Field Connection Terminals
- S) Sealed/Submersible

Conduit Length**

- 000) 0 feet [0 m]

Options

- N) None
- B) 1.5 inch
150# RF
flange connection
316SS

1" Thin MagProbe

DMP - [] - [] [] [] - [] [] [] [] - []

Probe Length

- A) 24 inches [457 mm]
- B) 48 inches [1220 mm]

Cable Length

- 020) 20 feet [6 m]
 - 050) 50 feet [15m]
 - 100) 100 feet [30 m]
- Maximum length: 990 feet [297 m]
in 10 ft. [3 m] increments

Conduit Type**

- N) None - Field Connection Terminals
- S) Sealed/Submersible

Conduit Length**

- 000) 0 feet [0 m]

Options

- N) None

**consult the Dynasonics factory for conduit availability and part numbers.

ISO-MOD Input/Output Modules



4-20 mA Output Module

Easily configured via jumper selections into either a passive or active transmission mode, the 4-20 mA Output Module interfaces with virtually all recording and logging systems by transmitting an analog current signal that is proportional to system flow rate. Independent 4 mA and 20 mA span settings are established in software. These entries can be set anywhere in the -30 to +30 FPS [-9 to +9 MPS] measuring range of the instrument. Output resolution of the module is 12-bits (4096 discrete points) and because of its low insertion loss characteristics, less than 5V typical, the module can drive up to 800 ohms of load with its internal 24V isolated power source.

Rate Pulse Output Module

The Rate Pulse Output Module is utilized to transmit information to external counters and PID systems via a frequency output that is proportional to system flow rate. This module does not source voltage at its output, it must be connected in an "open-collector" fashion with an external power source and pull-up resistor. Independent Zero and Span settings are established in software. These entries can be set anywhere in the -30 to +30 fps [-9 to +9 mps] measuring range of the instrument. Output resolution of the module is 12-bits (4,096 discrete points) and the maximum output frequency setting is 10,000 Hz. The MOSFET can support loads of 100V @ 9A.

Control Relay Module

Two independent SPDT (single-pole, double-throw, Form C) relays are contained in this module. The relay operations are user configured via software to act in either a flow rate alarm, system diagnostic alarm or totalizer/batching mode. The relays are rated for 200 VAC max. and have a current rating of 0.5A resistive load [175 VDC @ 0.25A resistive]. It is highly recommended that a slave relay be utilized whenever the Control Relay ISO-MOD is used to control inductive loads such as solenoids and motors.

General

ISO-MODs are epoxy encapsulated electronic communications modules that are simple to install and replace in the field. All modules are 2500V optically isolated from MFX power and earth grounds – eliminating the potential for ground loops and reducing the chance of severe damage in the event of an electrical surge. Eight ISO-MOD options are available including: 4-20 mA input and output, dual-relay, rate pulse, RS232, RS485, 200k-event datalogger and RTD heat-delivered option. MFX supports any two ISO-MOD input/output modules and all modules are field configurable by utilizing the front keyboard. Field wiring connections to ISO-MODs are quick and easy using pluggable terminals. Features of the various ISO-MODs are described below. Consult the Dynasonics factory for information regarding the RTD-BTU option.

RS232C Input/Output Module

The RS232 Module can be interfaced with serial communication ports of PCs, PLCs and SCADA systems, running a Modbus protocol, that are used to monitor flow rate information in piping systems. Baud rates up to 57.6 K are supported.

RS485 Input/Output Module

The RS485 Module allows up to 119 MFX systems daisy-chained on a single three-wire cable network – communications are via Modbus protocol. All meters are assigned a unique one byte serial number that allows all of the meters on the cable network to be accessed independently. Baud rates up to 57.6k and cable lengths to 1,000 feet [300 meters] are supported.

Data Logger Module

This powerful 200,000-event data logger/electronic stripchart recorder configures to match user applications. The logger stores time-stamped, high resolution (16-bit) data at user selected intervals ranging from 1 to 1,000 seconds. Configuration of and data retrieval from the logger can be accomplished in one of two ways:

- The module is hot-swappable – can be installed, removed or replaced within the flow meter without disconnecting power. The module can be carried in a shirt pocket back to the office and plugged into a serial port on a PC via the modules integral DB9 connector. This feature eliminates the requirement to carry a laptop computer to the flowmeter site.
- A hardware connection can be made to the Data Logger module which allows direct interface to the serial communication port of a PC, PLC or SCADA system. Historical data can be uploaded on command.

4-20 mA Input Module

One or two external sensors can be connected to the MFX through the 4-20 mA Input Module. The module has 24 Vdc sensor excitation voltage available to power sensors such as pressure transducers and temperature sensors - the two inputs are not isolated from each other. Input resolution of the module is 12-bits (4096 discrete points) and the input can be scaled into engineering units via the MFX keyboard.

MAGNETIC FLOWMETER

Series MFX

Hot-Tapped Insertion Probe

Dimensional Specifications

MECHANICAL DIMENSIONS: Inches [mm]

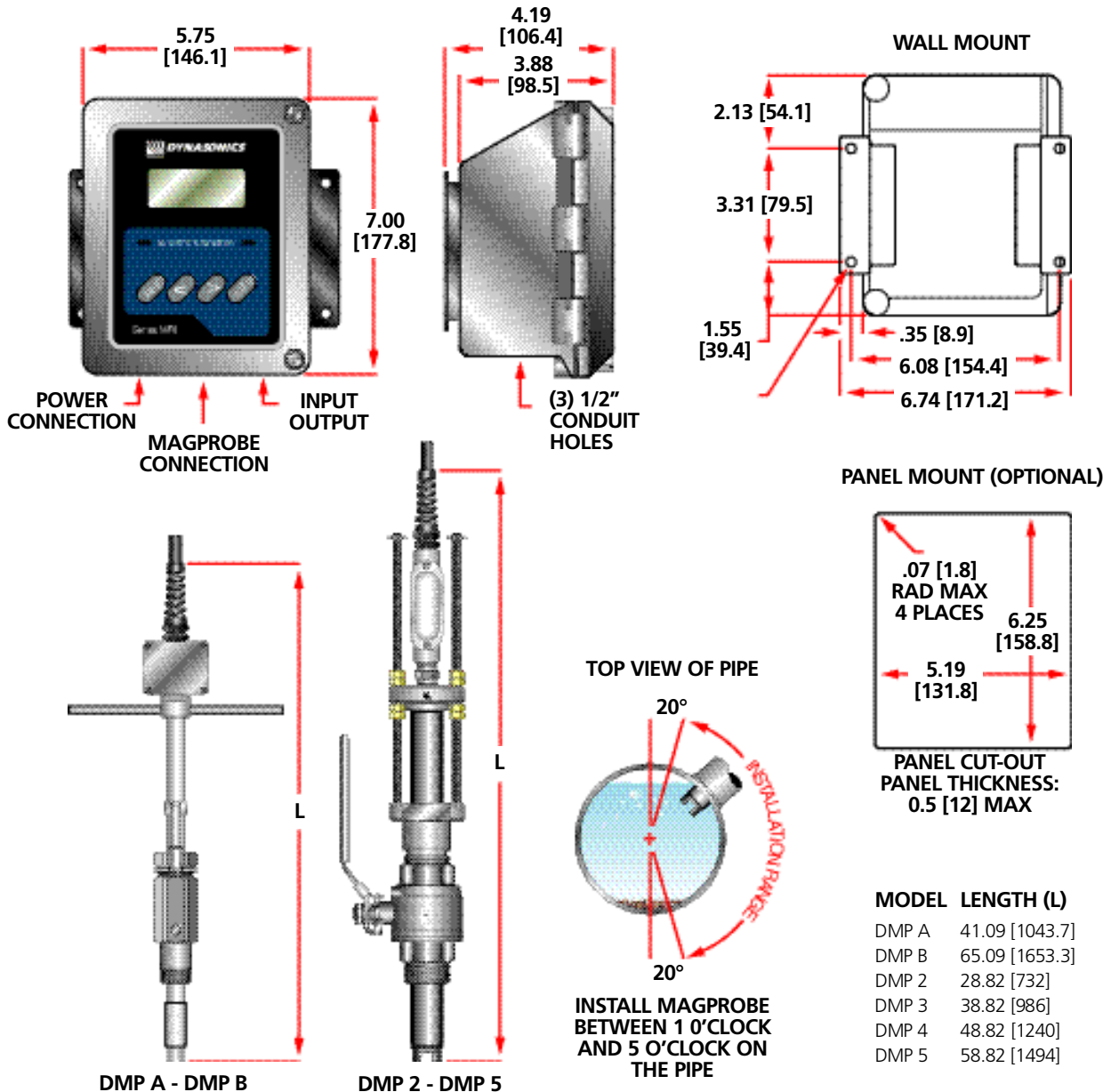

2200 South St. ■ Racine, WI 53404 ■ U.S.A.

Tel: 262.639.6770

800.535.3569 U.S.

Fax: 262.639.2267

800.732.8354 U.S.

www.dynasonics.com